

For direct connect to ECU pins:
 CLK to ECU CLK, pin 14
 RX to ECU TX, pin 15
 TX to ECU RX, pin 7

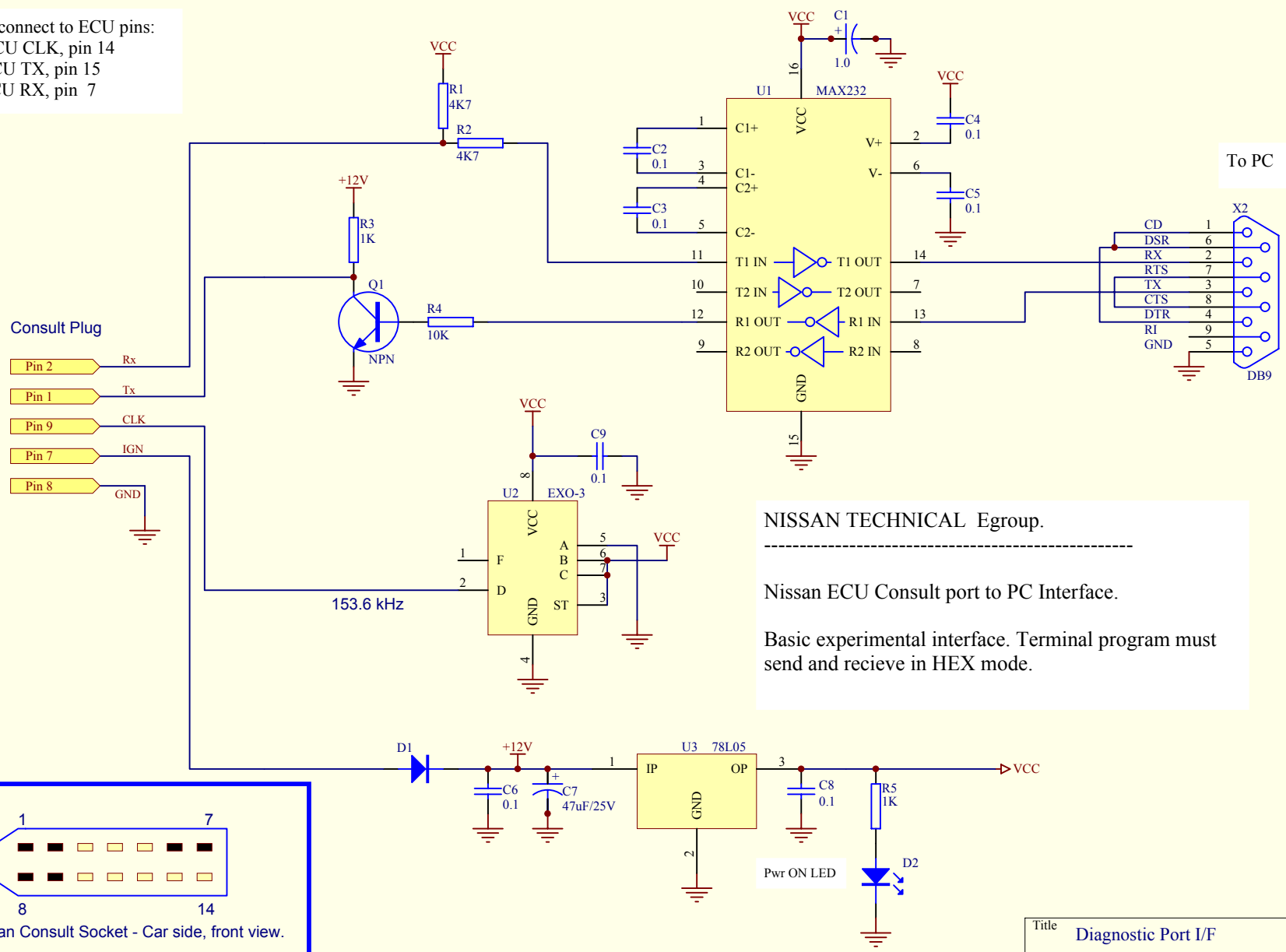

NISSAN TECHNICAL Egroup.

 Nissan ECU Consult port to PC Interface.
 Basic experimental interface. Terminal program must send and receive in HEX mode.

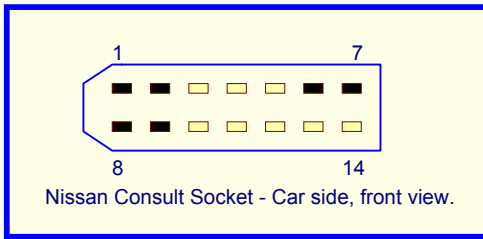

Title Diagnostic Port I/F		
Size A4	Number	Revision REV 1
Date: 23-Sep-2003	Sheet 1 of 1	
File: D:\Client98\Diagnostic Port IF v2.Sch	Drawn By: PL	